

# S262 Pump Testing and MicroSwitch Replacement

All service procedures below are to be executed with the power off, i.e., unplugged.

**Tools Required:** (1) 5/16" Nutdriver or wrench (1) Phillips Screwdriver  
(1) Flathead Screwdriver (1) Q-Tip Cotton Swab  
(1) Needlenose Pliers (1) 6" x 8" piece of Cardboard

## Preparation:

1. Read all pump and testing instructions carefully before checking and servicing pump on dehumidifiers.
2. Make sure you have all the parts and tools required to perform inspection, repair and upgrade as listed in these instructions.
3. Make sure the dehumidifier is disconnected from the power source before starting any of the following procedures.

## Removing Dehumidifier Cover and Accessing Pump

4. DrizAir 1200: Remove the six 3/8" bolts holding on the front cover in the following order. While unit is standing up, remove the two near the wheel axle. Place unit on its back, remove the two located on top, in front of cover. Last, remove the two located on bottom of unit near the front feet. All bolts can be identified because they are all 3/8". Remove front cover.

DrizAir 2400: Lay unit on its back and unscrew the four 7/16" bolts on the grey bucket. Remove bucket and turn upside down. Then set the pump on it, using it as a table.

5. DrizAir 1200, Carefully snip the zip tie holding the coiled power cord, and remove the two 5/16" mounting bolts located to the rear of the pump with nut driver.

DrizAir 2400, Carefully snip the zip tie holding the power cord in place inside unit. You may not need to snip the zip tie if there is already plenty of slack in the power cord to set pump on grey bucket. The objective is to remove the pump just far enough to access the two Phillips screws [#10], one on each side of pump cover [#1].

## Inspecting External Pump Components

6. With pump exposed, inspect " " clear drain tube entering pump on right side to insure it's properly seated into pump. If too short or kinked it may need to be replaced.
7. Pull tube out and verify bottom of tube has a 35-degree notch cut into it. This prevents a seal from occurring between the hose and bottom of reservoir tank. If seal occurs, water will back up in the drip tray and overflow.
8. Using screwdriver, remove pump-out tube from black check valve [#25] located on left side of pump. Be careful not to break fixture.
9. Unscrew check valve.
10. Look into the bottom of the check-valve assembly. Using needle nose pliers carefully remove bottom of check valve assembly by inserting one side of pliers approximately 1/8" into hole, grasp and pull carefully. A small bearing should fall out so be careful not to lose it. Now you can inspect for debris in assembly and clean accordingly. Clean and reinstall.

## Removing Pump

11. Remove pump from base by sliding to the left. While slightly lifting the silver pump shield up, pull pump up and out to left. Place piece of cardboard on top of refrigeration coils and rest pump gently on top of it, using it as a table.
12. Remove two pump cover screws [#10], and set pump cover [#1] aside.

## Inspecting Internal Pump Components

13. With cover removed, visually inspect microswitch [#7] for looseness. If loose, gently tighten screws [#8]. *Note*: Over tightening will cause switch to bind up inside and fail. If switch is snug and no parts missing, continue.
14. Check operation of microswitch by lifting float stem [#15] upward, listening for the switch activation "click" sound. Then, let float stem fall on its own, listening for the "click" going downward. Switch may need adjusting or replacement if "click" doesn't occur in both directions.

Adjustment: The microswitch needs to be level to its mounting peg. If switch is tilted too far back it will not activate microswitch lever. *Note*: Do not bend microswitch lever to compensate for unevenness. Loosen screws, adjust until level and gently re-tighten.

Replacement: If switch lever hangs up in either up or down direction, replace microswitch.

*Note*: Be careful not to over tighten mounting screws and nuts in either an adjustment or replacement switch situation. Also, be sure to include two locking washers [#6] per screw, one underneath head of screw [#8] and one prior to installing hex nut [#5].

15. Inspect to insure two "C" clips [#22] on float stem are in place, one above and one below microswitch lever.
16. Check to insure float moves freely up and down and is not restricted. If restricted, clean float stem [#15] and access port. A Q-Tip works well for this procedure.
17. Check to see if impeller [#20] is spinning freely by spinning the black plastic wheel located on top of motor.
18. Remove the remaining four Phillips screws [#10] from the top of the pump assembly and separate it from the blue reservoir tank [#16]. (Any missing microswitch screws or nuts may be found here.)
19. Inspect bottom of reservoir tank for debris and dirt build up. Clean accordingly.
20. Visually inspect impeller cover [#18] and gasket for cracks, warps or exposed gasket material.
21. Remove four impeller cover screws [#17] and check for debris in housing.
22. Assemble in reverse order. Run unit through several pump outs to insure repairs.

**DRI-EAZ PRODUCTS, INC.**

15180 Josh Wilson Road, Burlington WA 98233 •Tel: (360) 757-7776 Svc Fax (360) 757-6784 www.dri-eaz.com

## SPECIFIC PARTS LIST FOR PUMP

PART	REF#	ITEM	DRI-EAZ PART NUMBER	QTY 115v	QTY 230v
Cover - motor	154006	1	-	•	•
Fan	154031	2	-	•	•
Motor - 115v	979554	3	-	•	
Motor - 230v	979555	4	-		•
Plate - Motor	154021	4	-	•	•
Nut - Hex, 2-54	920035	5	08-00300	2	2
Washer - Lock, #2	921027	6	08-00301	4	4
Switch - VC Pump	950337	7	08-00298	•	•
Screw - 2-54 x 9/16"	901600	8	08-00299	2	2
Wire Nut	950403	9	-	•	•
Screw - 8-18 x _"	902436	10	-	16	16
Strain Relief	154038	11	-	•	•
Wiring Harness - 115v	951556	12	-	•	
Wiring Harness - 230v	951222	12	-		•
Lead Wire Assembly	951982	14	-	•	•

PART	REF#	ITEM	DRI-EAZ PART NUMBER	QTY 115v	QTY 230v
Float/Stem Assembly	154017	15	-	•	•
Tank	154004	16	-	•	•
Screw - 8-18 x _", SS	902431	17	-	5	5
Volute, Impeller Cover	154015	18	-	•	•
Seal Ring, Nitrile	928006	19	-	•	•
Impeller	154009	20	-	•	•
Cover, Tank	154005	21	-	•	•
Retaining Ring - circlip	923006	22	-	2	2
Washer, Slinger	921063	23	-	•	•
Washer, Lock, #8	921015	24	-	2	2
Check Value, VC Assy	154715	25	-	•	•
Adapter, _" MNPT x _" Hose	154037	26	-	•	•
Plug, Drain Hole	929600	27	-	•	•
Screw, 8-32 x _"	902421	28	-		

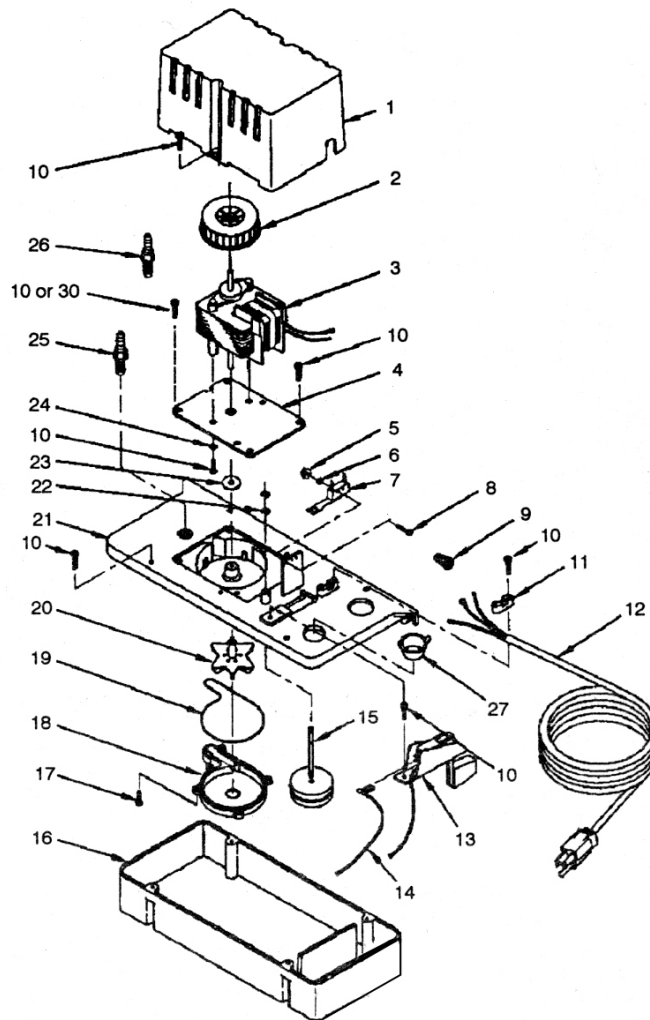

DRI-EAZ PRODUCTS, INC.

15180 Josh Wilson Road, Burlington WA 98233 •Tel: (360) 757-7776 Svc Fax (360) 757-6784 www.dri-eaz.com