

DrizAir 150 Dehumidifier

(Models: F91, F91-A, F91-SM, F91-230V)

Symbol Definition

- * - multiple components to choose from for different models: voltage, size, color, etc.
- + - if you order this item, you may need to order additional items marked with same number of +'s in order to upgrade or complete repair

| Find# | Part Description | Specifications/Model | Part # | | Qty |
|-------|--------------------------|-------------------------------------|----------|-----|------|
| | Connector, butt | 14-16 | 02-00013 | ea. | 5 |
| | Connector | Full Ins QS.250 Feml | 02-00135 | ea. | 1 |
| | Power Cord, 20' | 14-3 STJW-A | 02-00492 | ea. | 1 |
| 13 | Pump, Peristaltic 115v * | Peristaltic Pump, 115v, (-SM only) | 02-00494 | ea. | 1 |
| 32 | Strain Relief | Cord Strain Relief, Black, 115v, SM | 02-00499 | ea. | 1 |
| 53 | Coil, Solenoid 115v | Solenoid Coil, 115v, SM | 02-00777 | ea. | 1 |
| | Motor | 16W Unit Bearing | 02-00856 | ea. | 1 |
| | Switch, Dual Rocker | Switch, Dual Rocker | 02-01048 | ea. | 1 |
| 76 | Connector | 1/4", 18/22GA, Fem, Insul | 02-01117 | ea. | 1 |
| 54 | Coil, Solenoid 230v | Solenoid Coil, 230v | 02-01416 | ea. | 1 |
| 77 | Connector | 3/16", 18/22 GA, Fem, Insul | 02-01448 | ea. | 1 |
| | Washer | 1/4", Rivet, ZP | 03-00001 | ea. | 4 |
| 12 | Handle | Flush Mount Handle, Black | 03-00002 | ea. | 1 |
| 23 | Nylon Tie | 4" Nylon | 03-00012 | ea. | 6 |
| | Washer | #10 SS Flat | 03-00013 | ea. | 6 |
| | Nut | Nyloc 1/4-20 SS | 03-00017 | ea. | 4 |
| | Washer | 1/4-5/8 SAE SS | 03-00018 | ea. | 4 |
| 39 | Rivet | 1/4" x 1/2" Stl/Stl Zp | 03-00022 | ea. | 6 |
| 15 | Nut | #10-24, w/Star Washer, Zp | 03-00038 | ea. | 5 |
| | Bolt | 10-24 x 1/2 SS Hex Hd | 03-00430 | ea. | 6 |
| 7 | Rivet | 3/16 x 1/4" Stl/Stl, Paint Blk | 03-00432 | ea. | 8 |
| 16 | Clamp, Hose | 3/8 ID, Green | 03-00471 | ea. | 7 |
| | Nut | 10-24 SS Nyloc | 03-00491 | ea. | 6 |
| 48 | Hitch Pin | #17 Hitch Pin, Zp | 03-00501 | ea. | 2 |
| 47 | Washer | 1/2" ID x 1.25 OD x .06, SS | 03-00502 | ea. | 4 |
| 51 | Screw | 1/4-20 x 1.5 Oval Hed Phil Cs SS | 03-00503 | ea. | 4 |
| | Nut | 1/8-16 Nyloc SS | 03-00505 | ea. | 3 |
| 19 | Washer | 3/8 ID x 1.375" OD x .06, SS | 03-00506 | ea. | 3 |
| | Screw | #6-3/8 SS Phil Pan Hd | 03-00566 | ea. | 2 |
| | Push Mount | | 03-00771 | ea. | 5 |
| | Cable Tie | 11" | 03-00813 | ea. | 3 |
| | Rivet | 1/8" Al Short | 03-00901 | ea. | 4 |
| | Hose Clamp | 1/2" Yellow | 03-01059 | ea. | 5 |
| 20 | Bolt | 5/16-18 x 3/8" x 1.25", Shoulder | 03-01336 | ea. | 3 |
| 1 | Screw | #10-24 x 1/2" Zp | 03-01429 | ea. | 22 |
| | Bag | 9" x 15", 2 mil Poly | 06-00056 | ea. | 1 |
| | Label | Serial for Box | 07-00210 | ea. | 1 |
| 66 | Insulation | 3/4" ID x 1/2" Wall (8-1/2") | 08-00016 | ft. | .75' |

| Find# | Part Description | Specifications/Model | Part # | | Qty |
|-------|----------------------|---|----------|-----|-------|
| 31 | Drain Tube | Sub-Assy | 08-00019 | ea. | 1 |
| | Evaporator Coil | | 08-00752 | ea. | 1 |
| | Condenser Coil | | 08-00753 | ea. | 1 |
| 57 | Filter Dryer | Filter Dryer 1.5 Ton | 08-00754 | ea. | 1 |
| | R-22 Refrigerant | R-22 Refrigerant (24.7oz) | 08-00755 | set | 700g |
| 62 | Cork Tape Insulation | Cork Tape (3") | 08-00784 | ft. | 0.25' |
| 61 | Cork Tape Insulation | Cork Tape (8"), 115v, SM | 08-00784 | ft. | 0.67' |
| 61 | Cork Tape Insulation | Cork Tape (12") Compressor, 230v | 08-00784 | ft. | 1.0' |
| 67 | Cork Tape Insulation | Cork Tape (6") | 08-00784 | ft. | 0.50' |
| 68 | Cork Tape Insulation | Cork Tape (6") | 08-00784 | ft. | 0.50' |
| 60 | Insulation | For Pipe 3/8 x 3/8 Wall, (8") | 08-00785 | ft. | 0.67' |
| 70 | Insulation | 3/8" IDx3/8" Wall (2.0') | 08-00785 | ft. | 2.0' |
| | Hour Meter | | 12-00929 | ea. | 1 |
| | Rubber Tip | Rubber Tip for Rigid Handle, 1" | 13-00510 | ea. | 2 |
| 46 | Wheel | 9" ODx1/2" Bore, Blk Rubber | 13-00861 | ea. | 2 |
| 38 | Cap | 3/8" ID x 1" Blk Vinyl | 13-01056 | ea. | 2 |
| | Plug End, Metal | 1" Metal Plug End | 13-01190 | ea. | 2 |
| 18 | Tube, Vinyl | 1/4" x 3/8" (14-1/2") | 15-00195 | ft. | 1.2' |
| 36 | Tube, Vinyl | 1/4" ID x 3/8" OD, Vinyl (40' pc, only) | 15-00195 | ft. | 40' |
| 79 | Tube, Vinyl | 1/4" x 3/8" (10") | 15-00195 | ft. | 0.83' |
| | Tube | 1/4" ID, Neoprene, (12") | 15-00495 | ft. | 1' |
| | Tubing | 3/8" ID x 1/2" OD PVC, Vinyl | 15-01058 | ft. | 4' |
| | Tubing | 3/8" ID x 1/2" OD PVC, Vinyl | 15-01058 | ft. | 1.7' |
| | Tubing | Gravity Hose 3/8"ID x 1/2"OD | 15-01058 | ft. | 4 |
| | Fan Blade | 10" x 30 | 17-00858 | ea. | 1 |
| 74 | Tee | 1/4"x1/4"x1/4" AC/R Tee, Copper | 18-00756 | ea. | 1 |
| 55 | Valve, By-Pass | NEV-603 DXF, 5.8mm | 18-00760 | ea. | 1 |
| 64 | Damper, Vibration | 3/8" Vibration Damper | 18-00761 | ea. | 1 |
| | Damper, Vibration | 1/4" Vibration Damper | 18-00762 | ea. | 1 |
| 59 | Tee Copper | Copper Tee 3/8 -3/8 - 1/4 AC/R | 18-00764 | ea. | 1 |
| 37 | Fitting, Bulk Head | 1/4" BHU-22-04, w/Nut | 18-00812 | ea. | 1 |
| 58 | Valve, Shrader | 1/4" CD8404, Service Line | 18-00817 | ea. | 1 |
| | Fitting | 3/8x1/4 Red. Coupler | 18-01052 | ea. | 1 |
| | Fitting, Bulk Head | 3/8", BHU 22-06 (Special Order) | 18-01057 | ea. | 1 |
| | Elbow | 90 CopperAC/RLong | 18-01060 | ea. | 2 |
| 72 | Clamp | Clamp 1/4", Copper | 18-01132 | ea. | 1 |
| | Peristaltic Pump | | 23-00001 | ea. | 1 |
| | Coupling | 3/8" | 18-01137 | ea. | 2 |
| | Pump Plate | w/ Bushing (cover w/ 4 screw holes) | 23-00002 | ea. | 1 |
| | Pump Bushing | For Pump Plate | 23-00003 | ea. | 1 |
| | Roller Assembly | Peristaltic Pump Roller | 23-00004 | ea. | 1 |
| | Defrost Control Kit | Time/Temp (Timer) | 23-00972 | ea. | 1 |

DrizAir 150 Pictorial Drawing

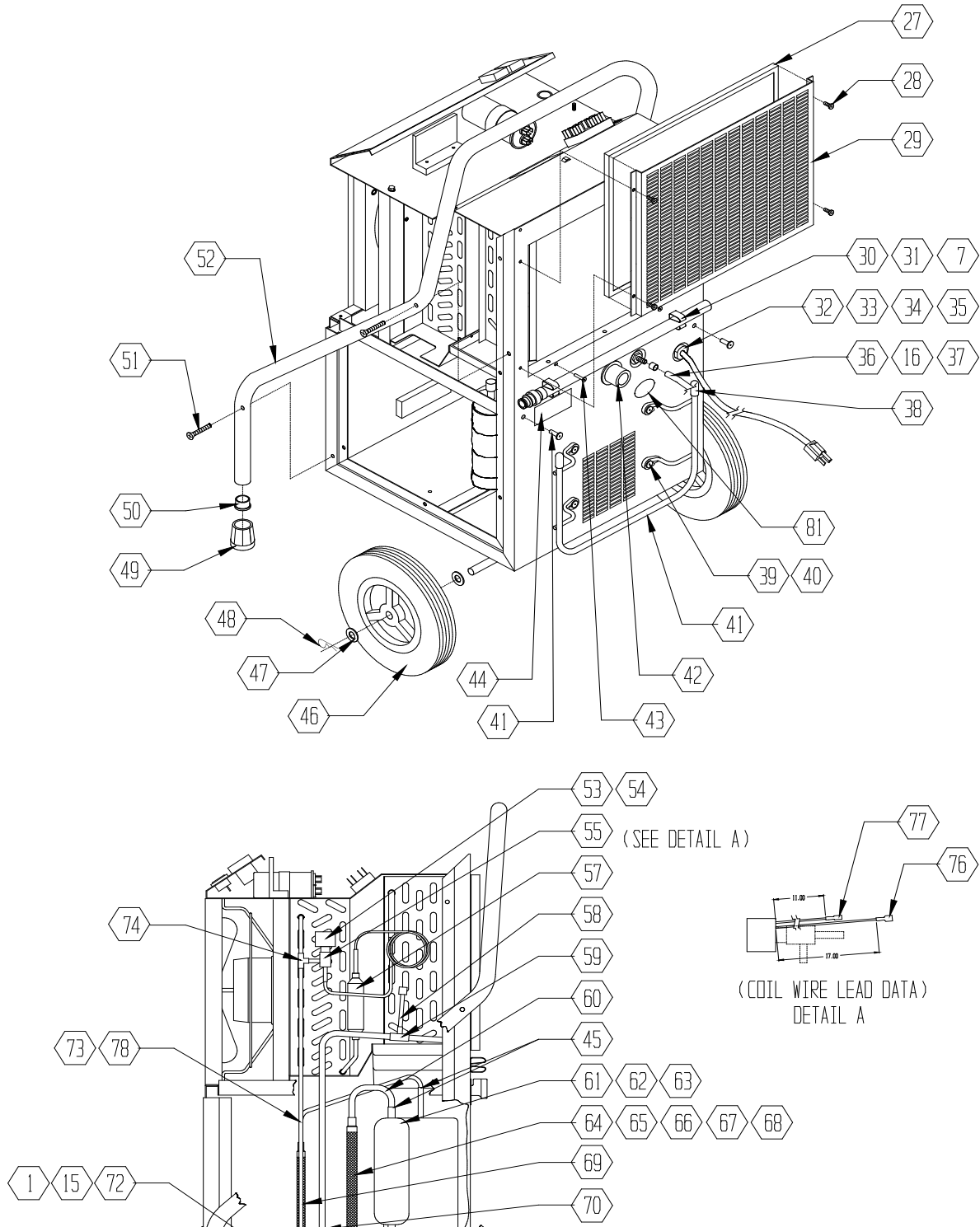

DrizAir 150 Pictorial Drawing

REFRIGERATION SYSTEM LAYOUT

F91G - Page 1

